

SMA8105-0316

SMA Jack Crimp For Bulkhead 50Ω

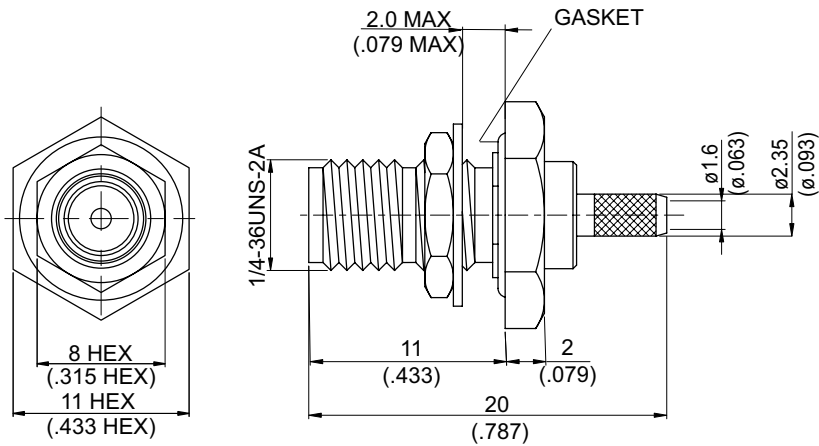

MOUNTING HOLE :

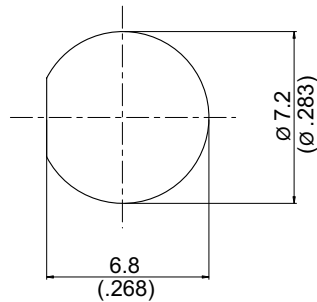

Parts	Material	Plating (Micro-inch)
Ferrule	Brass	Gold 5 Over Nickel 50 Over Copper 50
Hex Nut	Brass	Gold 5 Over Nickel 50 Over Copper 50
Lock Washer	Brass	Gold 5 Over Nickel 50 Over Copper 50
Gasket	Silicon	
Contact Pin	Beryllium Copper	Gold 20 Over Nickel 50 Over Copper 50
Insulator	Teflon	
Body	Brass	Gold 5 Over Nickel 50 Over Copper 50

Weight: 4.24 g

Suitable Cables: RG174, RG188, RG316, RG316-E, RG316-FEP

This part number complies with RoHS.

Notice: JYEBAO reserves the right to make modifications deemed appropriate.

## CABLE ASSEMBLY INSTRUCTION

SMA8105-0316

JYE BAO CO., LTD.

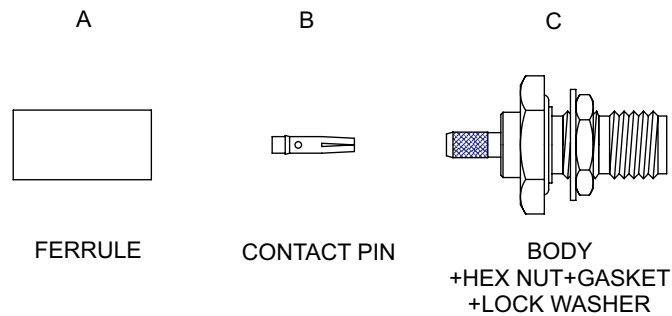

DIAGRAM	ASSEMBLY INSTRUCTION
	<p>Step 1: STRIP AS SHOWN.</p>
	<p>Step 2: SLIDE FERRULE "A" OVER CABLE. Step 3: PUT PIN "B" ON CENTER CONDUCTOR AND SOLDER IN "Y".</p>
	<p>Step 4: LOOSEN BRAIDING AND SLIDE CONNECTOR "C" IN PLACE.</p>
	<p>Step 5: SLIDE FERRULE "A" TOWARDS THE CONNECTOR "C" AND CRIMP.</p>

This part number complies with RoHS.

Notice: JYEBAO reserves the right to make modifications deemed appropriate.